



Ag9500

Power-Over-Ethernet Module for CCTV



1. Features

- IEEE802.3af compliant
- Standard CCTV package size
38mm x 38mm x 16mm (H)
- Low cost
- Input voltage range 36V to 57V
- Input diode bridges and output capacitor included
- Short-circuit protection
- Fixed Output Voltage
- 1500Vpk isolation (input to output)
- Silver Telecom "design-in" assistance

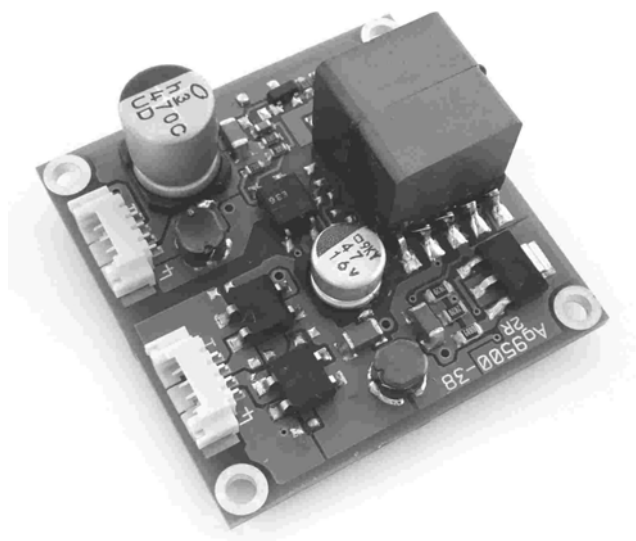

2. Description

The Ag9500 series of modules are designed to extract power from a conventional twisted pair Category 5 Ethernet cable, conforming to the IEEE 802.3af Power-over-Ethernet (PoE) standard.

The Ag9500 signature and control circuit provides the PoE compatibility signature and power classification required by the Power Sourcing Equipment (PSE) before applying up to 15W power to the port. The Ag9500 provides a Class 0 signature.

The DC/DC converter operates over a wide input voltage range and provides a regulated output. The DC/DC converter also has built-in short-circuit output protection.

Table of Contents

1. Features.....	1
2. Description.....	1
Table of Contents.....	2
Table of Figures.....	2
3. Ag9500 Product Selector.....	3
4. Block Diagram, Package, Connector and Pin Description.....	3
5. Functional Description.....	5
5.1. Inputs.....	5
5.2. PD Signature.....	5
5.3. Isolation.....	6
5.4. Power Classification.....	6
5.5. DC/DC Converter.....	6
5.6. Output Adjustment.....	6
5.7. Typical Connections.....	7
6. Typical Application.....	8
7. Typical Connections.....	9
8. Operating Temperature Range.....	9
9. Protection.....	10
10. Electrical Characteristics.....	10
10.1. Absolute Maximum Ratings ¹	10
10.2. Recommended Operating Conditions.....	11
10.3. DC Electrical Characteristics.....	11
11. Package.....	12

Table of Figures

Figure 1: Block Diagram.....	3
Figure 2: Ag9500 Package Format.....	4
Figure 3: Typical System Diagram.....	5
Figure 5: Typical Connection Diagram.....	7
Figure 6: Typical Application.....	8
Figure 7: Typical Connection.....	9
Figure 11: Ag9512 Operating Profile.....	10

3. Ag9500 Product Selector

Part Number†	Nominal Output Voltage	Maximum Output Power *	Marking
Ag9512-38	12.0V	12 Watts	12

*At 25°C with $V_{IN} = 48V$

† The Ag9500 fully meets the requirements of the RoHS directive 2002/95/EC on the restriction of hazardous substances in electronic equipment.

Table 1: Ordering Information

4. Block Diagram, Package, Connector and Pin Description

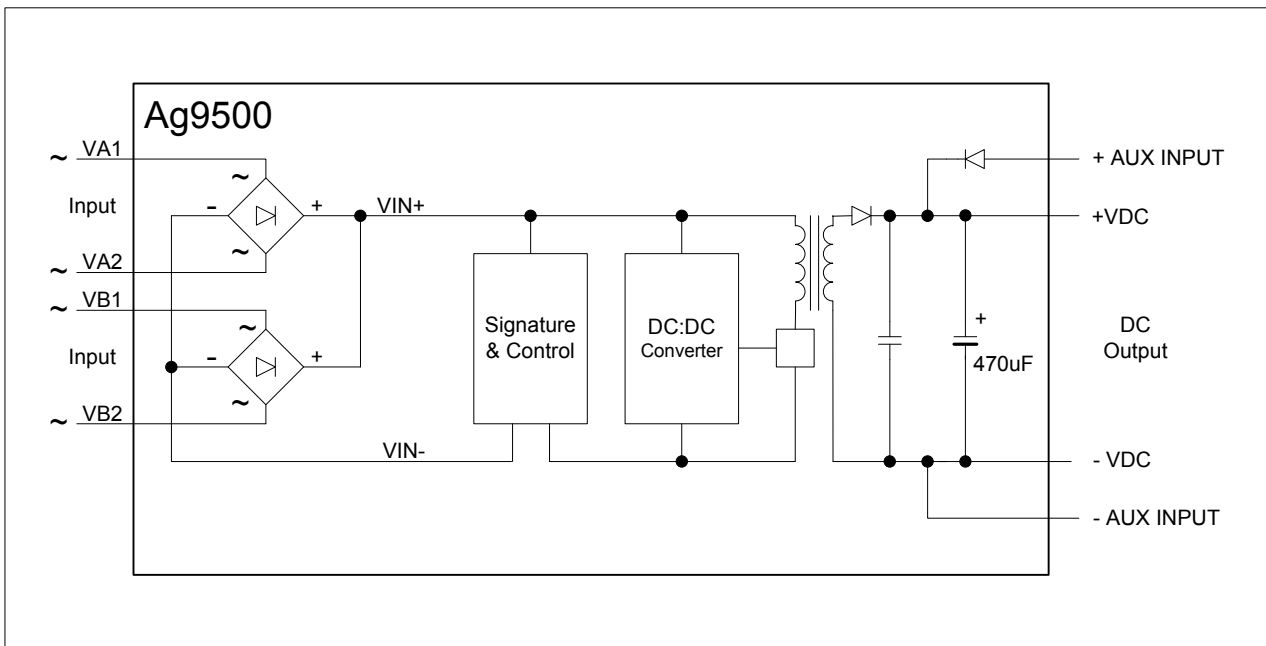

Figure 1: Block Diagram

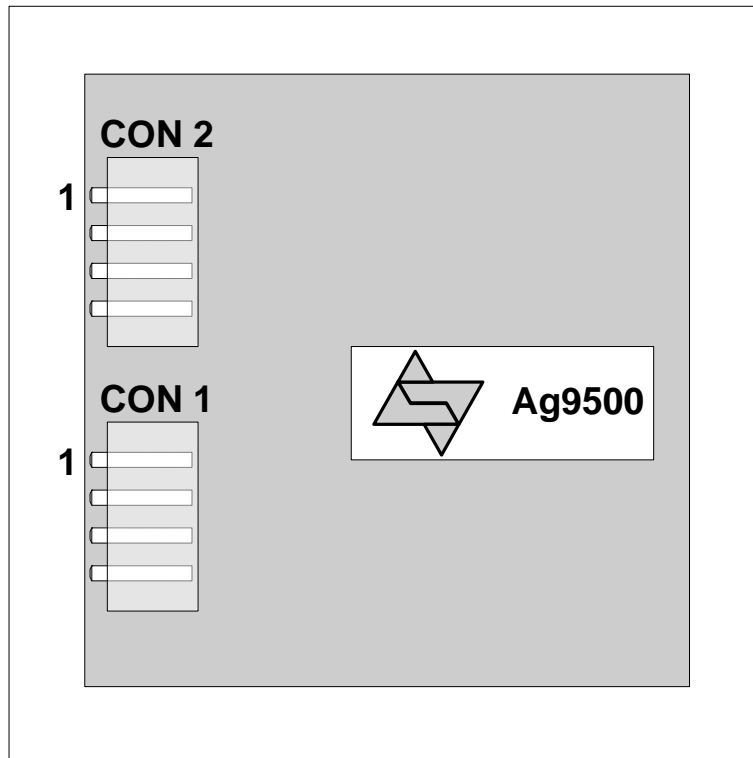

Figure 2: Ag9500 Package Format

Pin #	Name	Description
CON2 1	+ VAUX	DC Auxiliary input. This pin connects to the positive output of the auxiliary DC power supply.
CON2 2	- VAUX	DC Auxiliary input. This pin connects to the negative output of the auxiliary DC power supply.
CON2 3	-VDC	DC Return. This pin is the return path for the +VDC output.
CON2 4	+VDC	DC Output. This pin provides the positive regulated output from the DC/DC converter.
CON1 1	VA1	DC input. This pin connects to the output of the Ethernet transformer centre tap. Not polarity sensitive.
CON1 2	VA2	DC input. This pin connects to the output of the Ethernet transformer centre tap. Not polarity sensitive.
CON1 3	VB1	DC input. This pin connects to the Ethernet cable spare pair. Not polarity sensitive.
CON1 4	VB2	DC input. This pin connects to the Ethernet cable spare pair. Not polarity sensitive.

Table 2: Connector and Pin Description

5. Functional Description

5.1. Inputs

The Ag9500 is compatible with equipment that uses either the data pair or the spare pair for power, see Figure 3: Typical System Diagram. It is specified that the PSE must not apply power to both inputs at the same time (Refer to IEEE802.3af for more information).

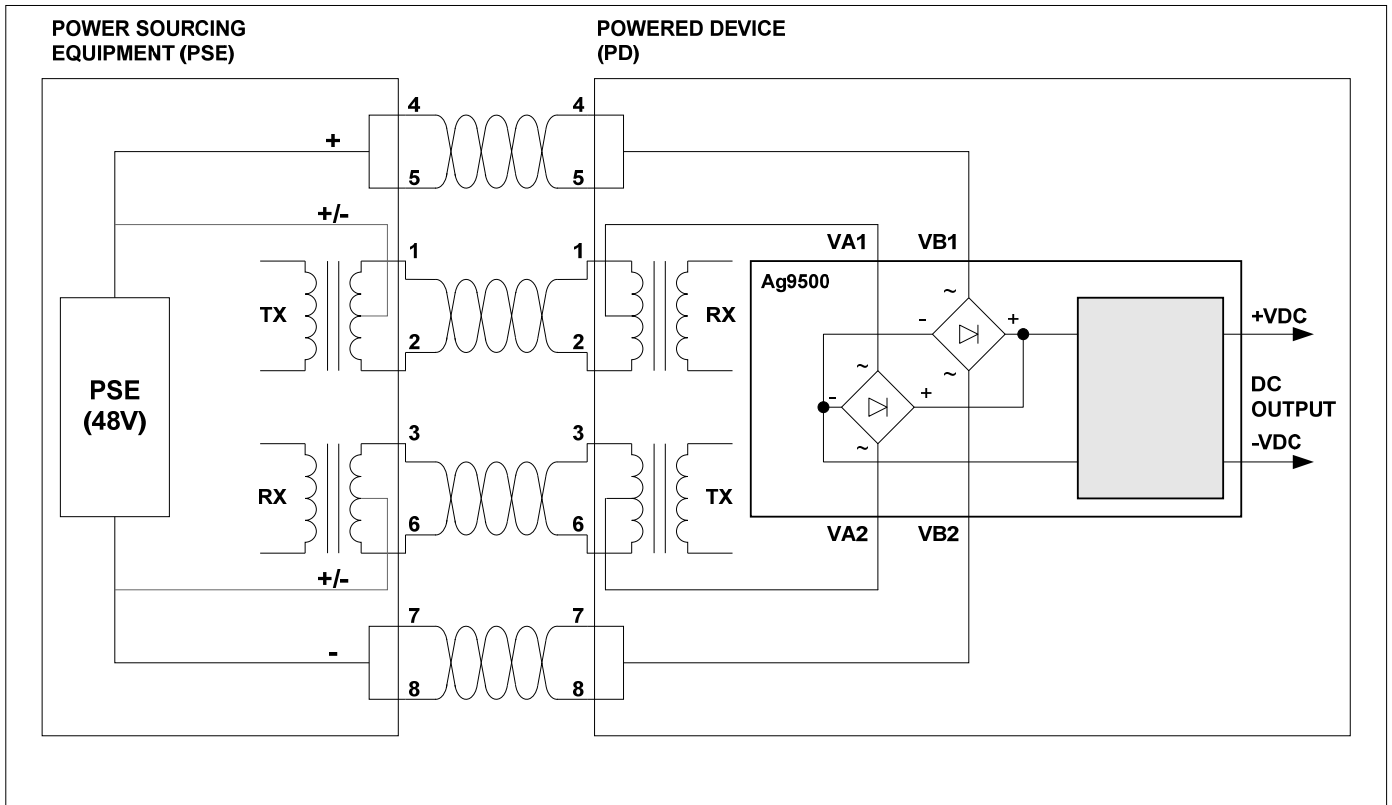

Figure 3: Typical System Diagram

Although IEEE802.3af does not cover 1000 BASE-T (Gigabit) Ethernet, it is possible to interface the Ag9500 to a Gigabit network. See application note “ANX-1000BASE-T-CONNECTIONS”, section “Dual input modules with internal bridge rectifiers” for details.

5.2. PD Signature

When the Ag9500 is connected to the Cat 5e cable, it will automatically present a Powered Device (PD) signature to the Power Sourcing Equipment (PSE) or Midspan Equipment, when requested. The equipment will then recognise that a powered device is connected to that line and supply power.

5.3. Isolation

To meet the safety isolation requirements of IEEE802.3af section 33.4.1 a Powered Device (PD) must pass the electrical strength test of IEC 60950 sub clause 6.2. This calls for either a) 1500Vac test or b) 1500Vpk impulse test. The Ag9500 is specified to meet the 1500Vpk impulse test.

5.4. Power Classification

The Ag9500 is fixed internally for Class 0 (0.44 Watts to 12.95 Watts) operation.

5.5. DC/DC Converter

The Ag9500's DC/DC converter provides a regulated low ripple and low noise output that has built-in short-circuit output protection – refer Table 1: Ordering information for voltage and power ratings

Filtering is provided internally for EMC reduction. However overall EMC performance must be verified in the final system configuration as this can cause large changes in EMC.

5.6. Output Adjustment

The Ag9500 has an internally fixed output voltage. External adjustment is not provided.

5.7. Typical Connections

The Ag9500 has internal diode bridges and a large 470uF output capacitor so it requires no external components, as shown in Figure 5: Typical Connection Diagram.

The value of the optional output capacitor C1 is related to the maximum load step change that the output needs to drive. For 1 amp load step the internal 470uF capacitor is sufficient. In unusual applications where the output needs to cope with very high load step changes, an extra 470µF may be fitted externally. This can be a standard low cost electrolytic and does not need to be a low ESR type.

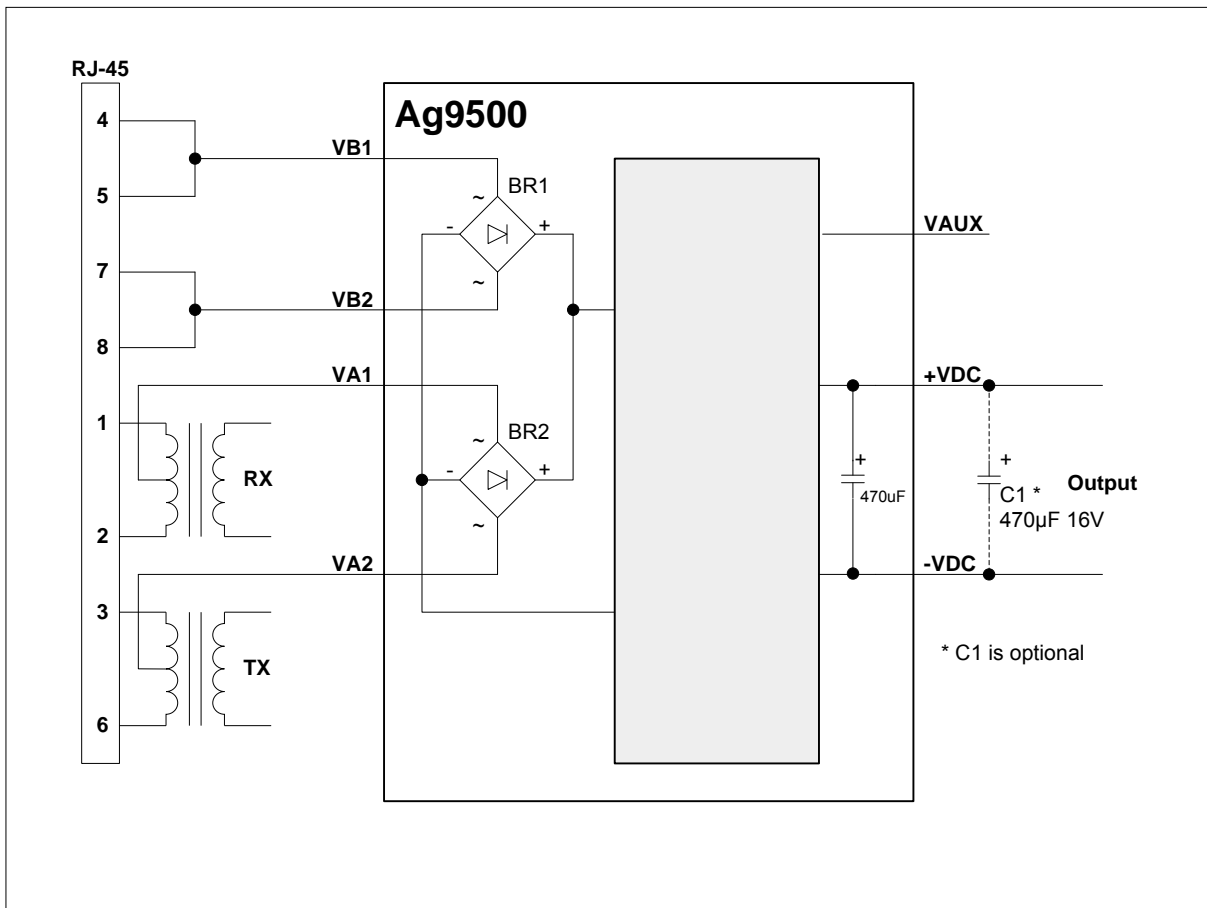

Figure 4: Typical Connection Diagram

6. Typical Application

The Ag9500 can be used in numerous applications but is specifically designed for CCTV. In the example shown in Figure 6: Typical Application, the data outputs from the Ethernet switch are connected to the inputs of a midspan PSE. The midspan will then add power (to the data) on each output that supports Power over Ethernet (PoE).

In this example port 1 is connected to an ethernet camera using and Port 2 is connected to a wireless access point. Both of these devices have a built-in Ag9500. When the midspan is switched on (or when the device is connected), the midspan will check each output for a PoE signature. On ports 1 and 2 the Ag9500 will identify themselves as PoE enabled devices and the midspan will supply both data and power to these peripherals.

The other ports (shown in this example) will not have a PoE signature and the midspan will only pass the data through to these peripherals. The midspan will continuously monitor each output to see if a PoE enabled device has been added or removed.

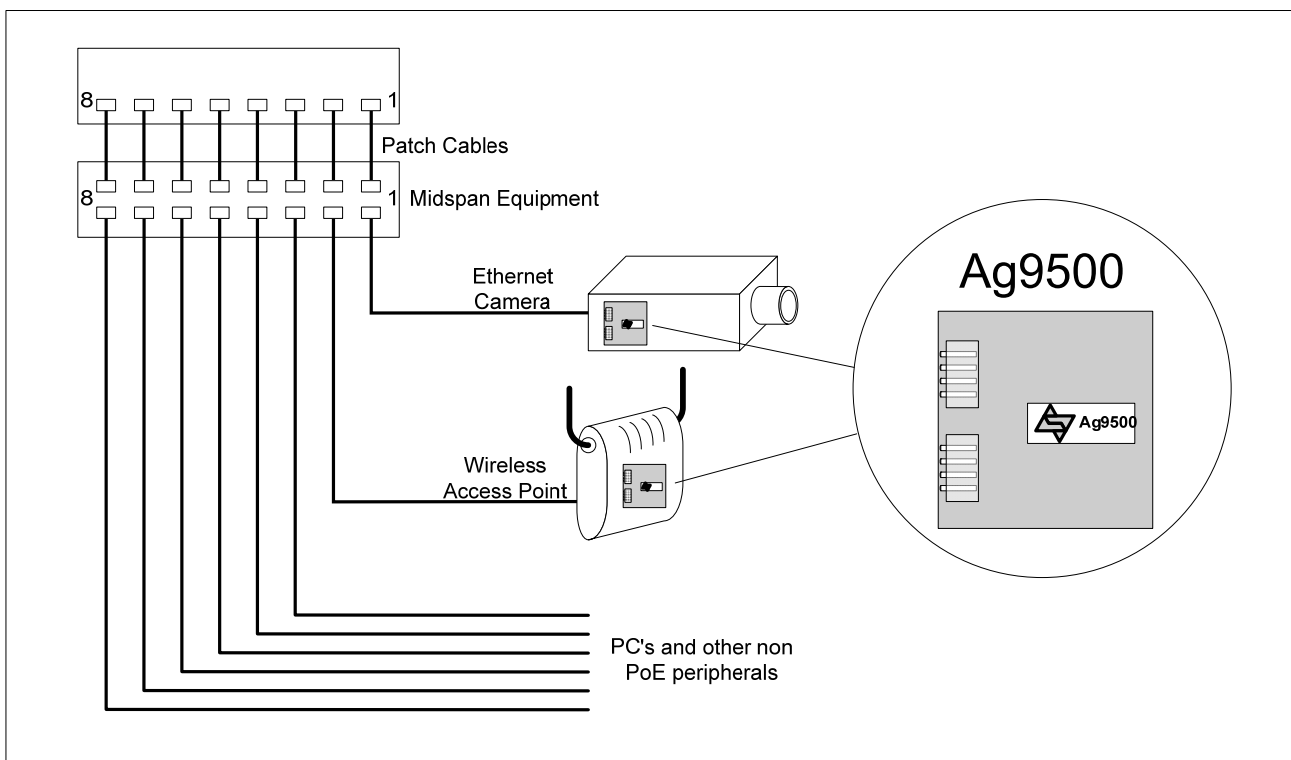

Figure 5: Typical Application

7. Typical Connections

Figure 7: Typical Connection gives an example of the connecting cables needed for the Ag9500. The connector used on the module is the Yeonho 12505WR-04. The matching cable housing needed is the Yeonho 1205HS-04 fitted with 4 x 1205TS terminals.

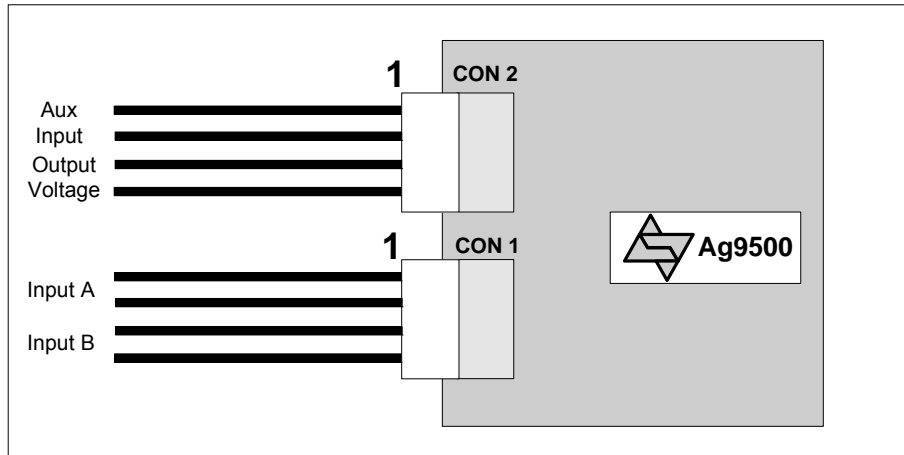

Figure 6: Typical Connection

8. Operating Temperature Range

Because the Ag9500 is a power component, it will generate heat, so it is important that this be taken into consideration at the design stage.

The heart of the Ag9500 is a DC/DC converter, which like any other power supply will generate heat. The amount of heat generated by the module will depend on the load it is required to drive and the input voltage supplied by the PSE. The information shown within this section of datasheet is referenced to a nominal 48Vdc input voltage supplied by the PSE.

The Ag9500 has a maximum ambient operating temperature of 70°C see Figure 9. These results are in still air without any heatsinking, the performance of the Ag9500 can be improved by forcing the airflow over the part or by using a heatsink (see the Ag9500 application note on heatsinking for more information).

The output stage of the Ag9500 has no built-in thermal protection. To prevent the module from being damaged by excessive power dissipation it is recommended that the module be powered by an IEEE802.3af compliant PSE or Midspan equipment. However the Ag9500 may be powered by a user designed power supply which should include thermal and over current protection.

Because each application is different it is impossible to give fixed and absolute thermal recommendations. However it is important that any enclosure used has sufficient ventilation for the Ag9500 and a direct airflow if possible.

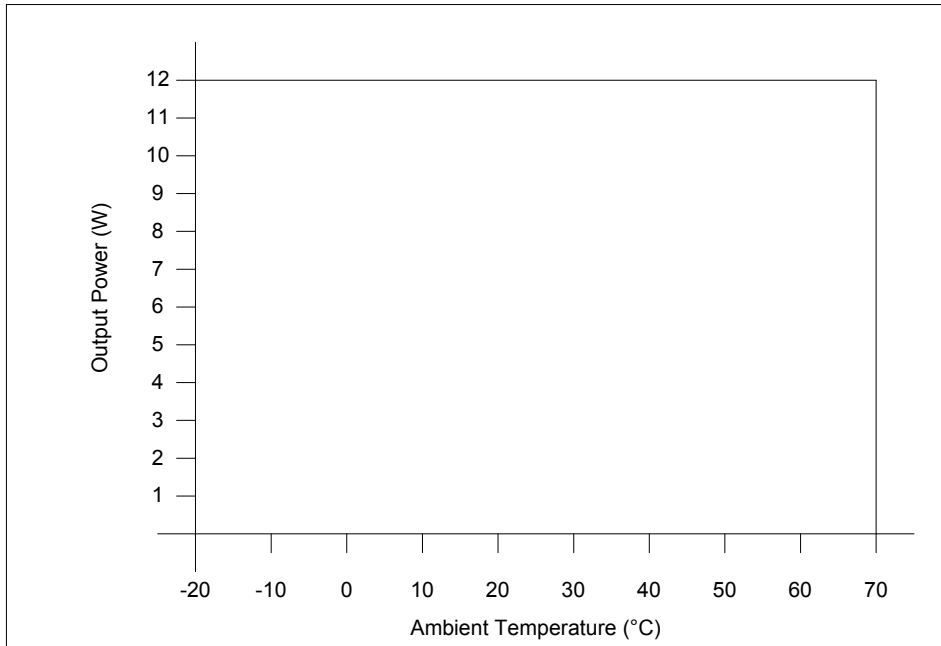

Figure 7: Ag9512 Operating Profile

9. Protection

The Ag9500 has an on-board SMAJ58CA Transorb to reduce the risk of over-voltages (exceeding the 80V maximum rated surge voltage) from damaging the inputs; see Apps Note “ANX-POE-Protection” for more detail.

10. Electrical Characteristics

10.1. Absolute Maximum Ratings¹

	Parameter	Symbol	Min	Max	Units
1	DC Supply Voltage	V_{CC}	-0.3	60	V
2	DC Supply Voltage Surge for 1ms	V_{SURGE}	-0.6	80	V
3	Storage Temperature	T_S	-40	+100	°C

Note 1: Exceeding the above ratings may cause permanent damage to the product. Functional operation under these conditions is not implied. Maximum ratings assume free airflow.

10.2. Recommended Operating Conditions

	Parameter	Symbol	Min	Typ	Max	Units
1	Input Supply Voltage ¹	V _{IN}	36	48	57	V
2	Under Voltage Lockout	V _{LOCK}	30		36	V
3	Operating Temperature ²	T _{OP}	-20	25	70	Ta / °C

Note 1: With minimum load

2: See Section 8. Operating Temperature Range

10.3. DC Electrical Characteristics

	DC Characteristic	Sym	Min	Typ ¹	Max	Units	Test Comments
1	Nominal Output Voltage	+VDC	11.5	12.0	12.5	V	Ag9512
2	Output Current (V _{IN} = 48V)	I _{OUT}			1.0	A	Ag9512
3	Line Regulation	V _{LINE}		0.1		%	@ 50% Load
4	Load Regulation	V _{LOAD}		1		%	@ V _{IN} =48V
5	Output Ripple and Noise	V _{RN}		20		mVp-p	@ Max load
6	Minimum Load	R _{LOAD}	150			mA	for specified regulation
7	Short-Circuit Duration ²	T _{SC}			∞	sec	
8	Efficiency @ 80% Load	EFF		84		%	Ag9512
9	Isolation Voltage (I/O)	V _{ISO}			1500	V _{pk}	Impulse Test
10	Temperature Coefficient	TC		0.02		%	Per °C

Note 1: Typical figures are at 25°C with a nominal 48V supply and are for design aid only. Not Guaranteed

2: Continuous short circuit duration is applicable at 25°C ambient temperature in free air. At higher temperatures or with restricted airflow (e.g. in a sealed enclosure) the duration will need to be limited to avoid overheating.

11. Package

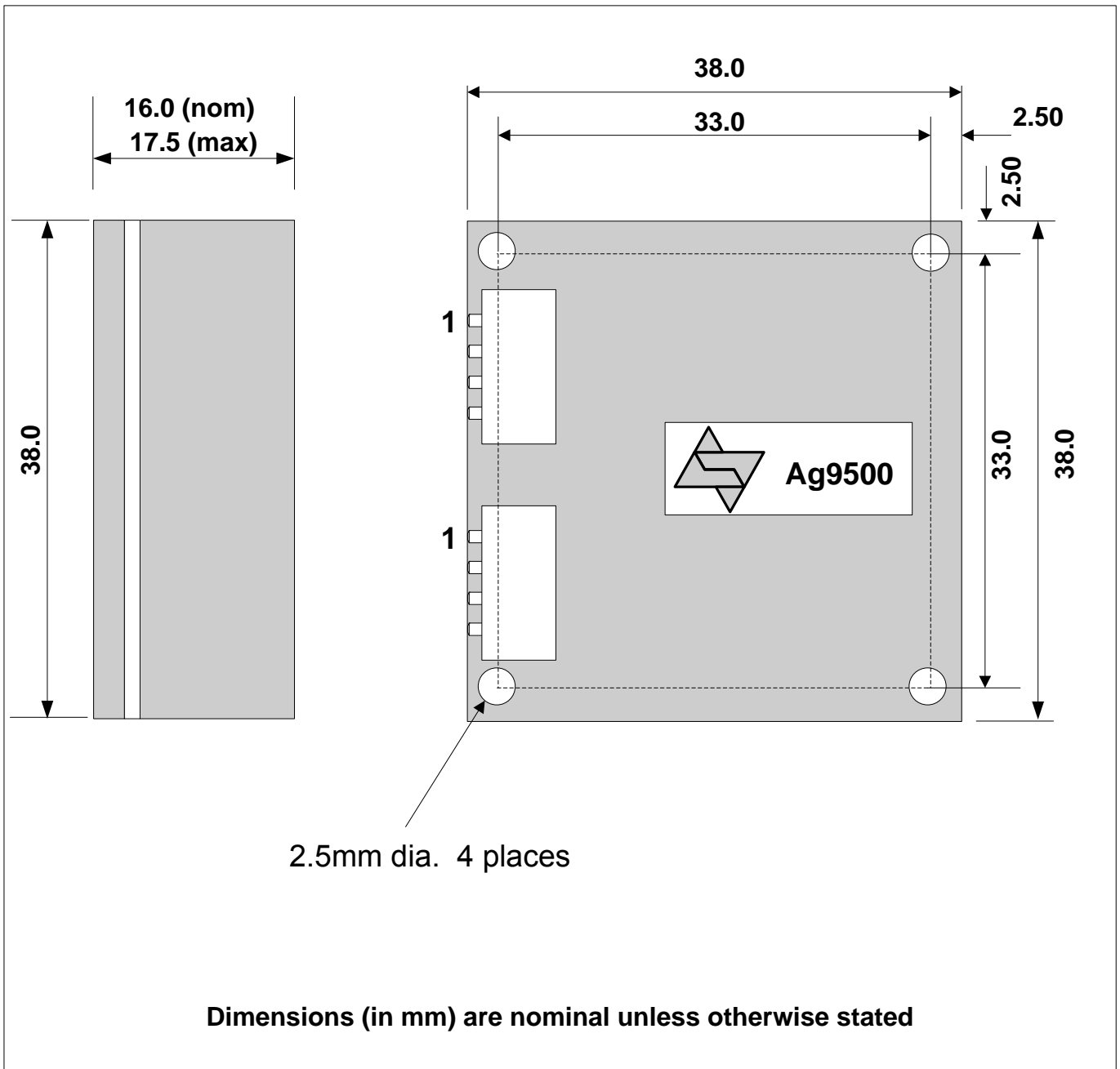

Information published in this datasheet is believed to be correct and accurate. Silver Telecom assumes no liability for errors which may occur or for liability otherwise arising out of use of this information or infringement of patents which may occur as a result of such use. No license is granted by this document under patents owned by Silver Telecom or licensed from third parties by Silver Telecom. The products, their specification and information appearing in this document are subject to change by Silver Telecom without notice.