



Ag9300

POE Module for Security Cameras and Systems



1. Features

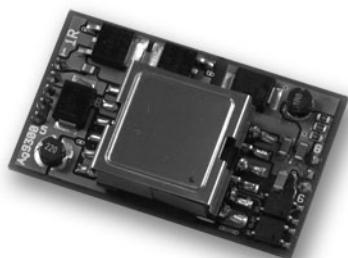

- PSU Module for POE, 12Vdc and 24Vac
- POE input voltage 36Vdc to 57Vdc
DC input voltage 12Vdc to 48Vdc
AC input voltage 18Vac to 30Vac
- IEEE802.3af compliant
- Small Dual In-Line (DIL) package size – 50.6mm (L) x 30mm (W)
- Overload and short-circuit protection
- Adjustable Output
- Thermal Cut Off
- Single High efficiency DC/DC converter
- 1500Vdc isolation (input to output)
- Silver Telecom “design-in” assistance

2. Description

The Ag9300 Power-over-Ethernet (PoE) module is designed to extract power from a conventional twisted pair Category 5 Ethernet cable, conforming to the IEEE 802.3af PoE standard. With an additional auxiliary input that will accept a DC or AC voltage.

This module is ideal for security cameras where 12Vdc or 24Vac is used. It can also be used with other security systems such as door access or sensors that have an input voltage of 12Vdc to 48Vdc or 18Vac to 30Vac.

The Ag9300 signature and control circuit provides the PoE compatibility signature and power classification required by the Power Sourcing Equipment (PSE) before applying up to 15W power to the port. The Ag9300 is compatible with Class 0 to Class 3 equipment.

The high efficiency DC/DC converter operates over a wide input voltage range with a low ripple and low noise output. The DC/DC converter also has built-in output overload, output short-circuit and over-temperature protection and provides a 1500Vdc (input to output) isolation barrier.

Table of Contents

1. Features.....	1
2. Description.....	1
Table of Contents.....	2
Table of Figures.....	2
3. Ag9300 Product Selector [†]	3
4. Pin Description.....	4
5. Functional Description.....	5
5.1. Inputs.....	5
5.2. PD Signature.....	6
5.3. Isolation.....	6
5.4. Power Classification.....	6
5.5. DC/DC Converter.....	7
5.6. Output Adjustment.....	7
5.7. Typical Connections.....	8
6. Typical Application.....	9
7. Typical Recommendations.....	10
8. Operating Temperature Range.....	10
9. Protection.....	11
10. Electrical Characteristics.....	12
10.1. Absolute Maximum Ratings*.....	12
10.2. Recommended Operating Conditions.....	12
10.3. DC Electrical Characteristics*.....	12
11. Package.....	13

Table of Figures

Figure 1: Block Diagram with External Components.....	3
Figure 2: Ag9300 DIL Package Format.....	4
Figure 3: Typical System Diagram.....	5
Figure 4: Class Programming Option.....	6
Figure 5: Output Adjustment.....	7
Figure 6: Typical Connection Diagram.....	8
Figure 7: Typical Application.....	9
Figure 8: Typical Layout.....	10
Figure 9: Ag9300 Operating Profile.....	11

3. Ag9300 Product Selector[†]

Part Number	Nominal Output Voltage	Maximum Output Power *	Marking	Package
Ag9312-D	12V	12 Watts	12	DIL

*At 25°C with $V_{IN} = 48V$

† The Ag9300 fully meets the requirements of the RoHS directive 2002/95/EC on the restriction of hazardous substances in electronic equipment.

Table 1: Ordering Information

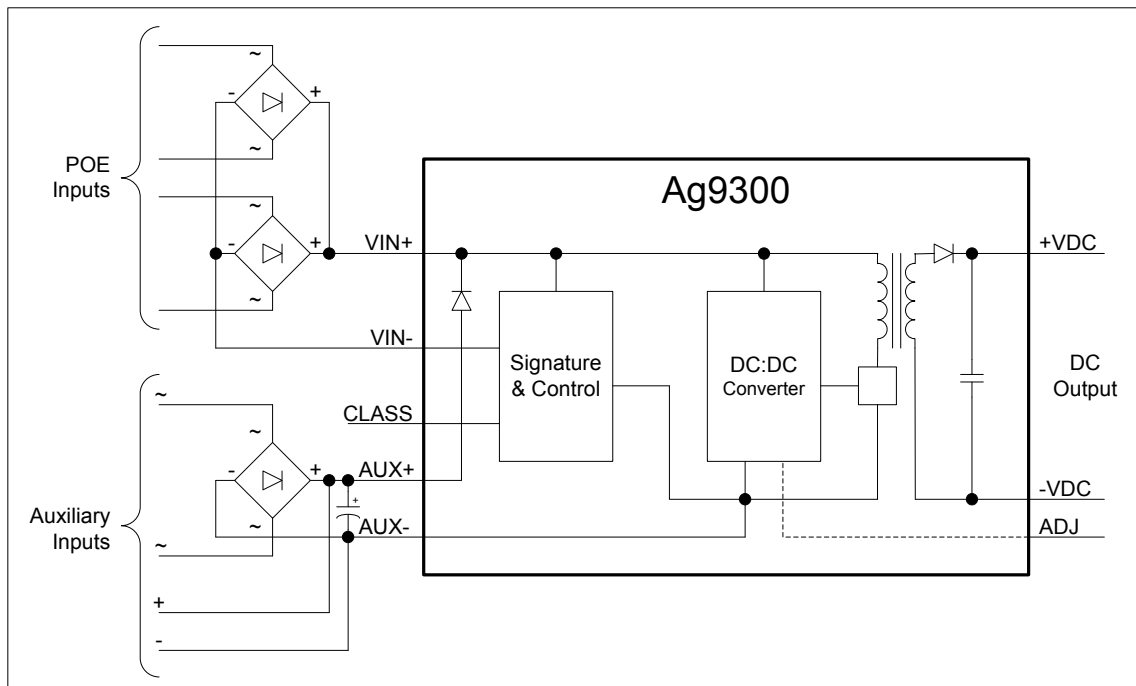

Figure 1: Block Diagram with External Components

4. Pin Description

Pin #	Name	Description
1	AUX-	AUX Direct Input -. This pin connects to the negative (-) output of an auxiliary DC power supply or AC supply via a rectifier.
2	AUX+	AUX Direct Input +. This pin connects to the positive (+) output of an auxiliary DC power supply or AC supply via a rectifier.
3	VIN+	POE Direct Input +. This pin connects to the positive (+) output of the POE input bridge rectifiers.
4	CP	Class Programming. Connecting an external resistor to VIN- will change the current class of the module. With no resistor fitted the Ag9300 will default to Class 0.
5	VIN-	POE Direct Input -. This pin connects to the negative (-) output of the POE input bridge rectifiers.
6	ADJ	Output Adjust. The output voltage can be adjusted from its nominal value, by connecting an external resistor from this pin to either the +VDC pin or the -VDC pin.
7	-VDC	Negative DC Output. This pin provides the negative regulated output from the DC/DC converter.
8	+VDC	Positive DC Output. This pin provides the positive regulated output from the DC/DC converter.

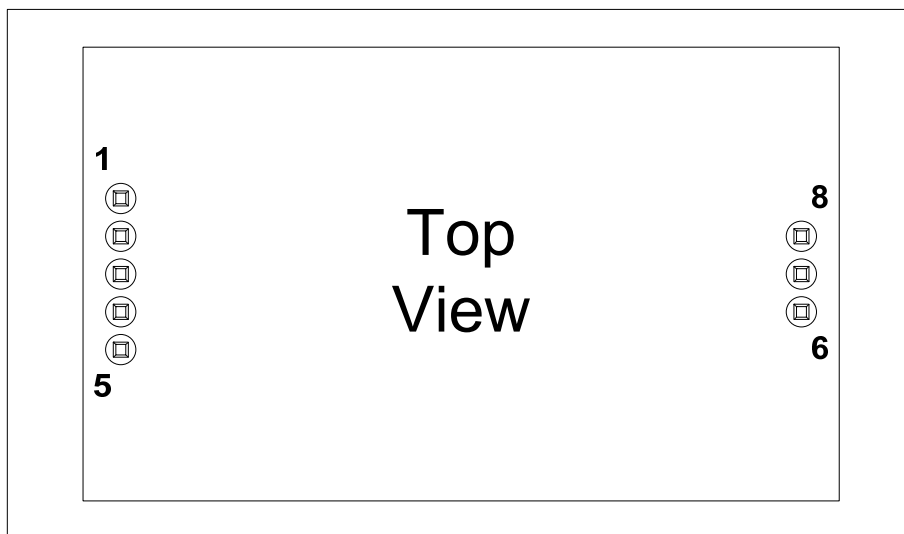

Figure 2: Ag9300 DIL Package Format

5. Functional Description

5.1. Inputs

The Ag9300 has two inputs: -

The VIN input is for POE and is connected to two external bridge rectifiers, see Figure 3. This allows the Ag9300 to be compatible with equipment that use the different power options (power on the Data Pair or power on the Spare Pair).

The AUX (auxiliary) input can be connected directly to a DC power supply. This input has a wide input range of 12Vdc to 48Vdc and has internal polarity protection, see Figure 1. The input can also be connected to an AC power supply in the range of 18Vac to 30Vac via a bridge rectifier and smoothing capacitor (recommended 470µF).

If power is applied to both the VIN and AUX inputs, then the highest voltage will take priority. For example if a PSE (Power Sourcing Equipment) is supplying 48V to the VIN input and a 12Vdc supply is connected to the AUX input, the current will be drawn from the PSE.

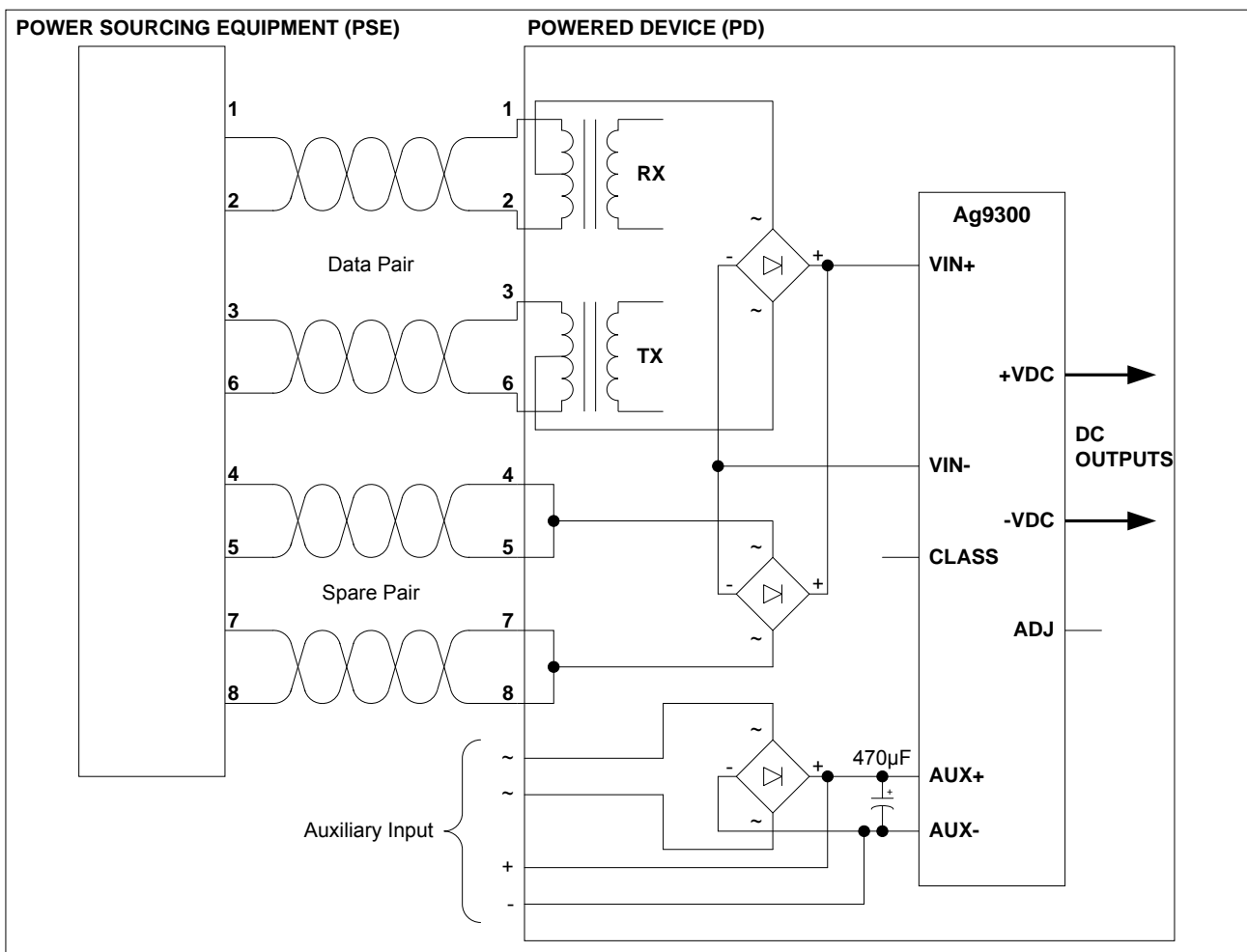

Figure 3: Typical System Diagram

5.2. PD Signature

When the Ag9300 VIN input is connected to the Cat 5e cable, it will automatically present a Powered Device (PD) signature to the PSE, when requested. The PSE will recognise that a PD is connected to that line and supply power.

5.3. Isolation

To meet the safety isolation requirements of IEEE802.3af section 33.4.1 a PD must pass the electrical strength test of IEC 60950 sub clause 6.2. This calls for either a) 1500Vac test or b) 1500Vdc impulse test. The Ag9300 is specified to meet the 1500Vdc impulse test. It is also important that the tracks on either side of the isolation barrier have at least a 3mm clearance, see Figure 8 for more information.

5.4. Power Classification

This is optional from the PSE and is used for power management. The Ag9300 VIN input allows the current class to be externally programmed by connecting a resistor between the CLASS and VIN- pins, see Figure 4. If no resistor is fitted the Ag9300 will default to Class 0, a full list of programming resistor values are shown in Table 2.

CLASS	Programming Resistance (Ohms)	Min Power (W)	Max Power (W)
0	Do not fit	0.44	12.95
1	698 \pm 1%	0.44	3.84
2	383 \pm 1%	3.84	6.49
3	249 \pm 1%	6.49	12.95
4	TBD	Reserved	Reserved

Table 2: Class Programming

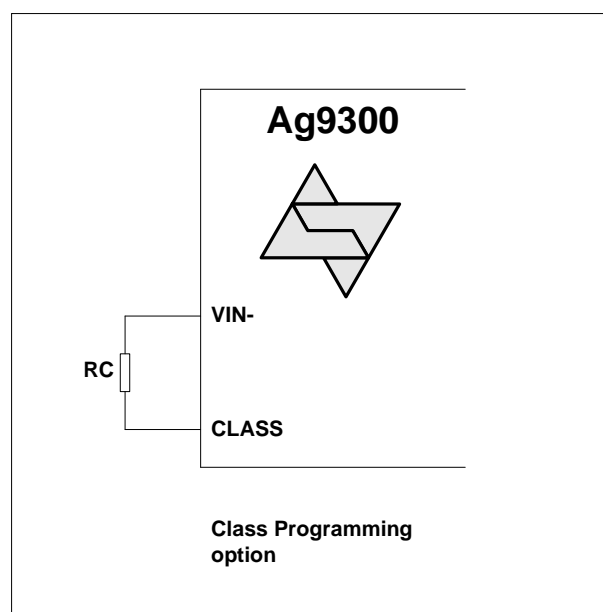

Figure 4: Class Programming Option

5.5. DC/DC Converter

The Ag9300's DC/DC converter provides a regulated 12V (nominal) output with low ripple and low noise. The DC/DC converter also has built-in output overload and short-circuit protection. The Ag9300 also has thermal protection; which will shutdown the DC/DC converter if triggered.

5.6. Output Adjustment

The Ag9300 has an ADJ pin, which allows the output voltage to be increased or decreased from its nominal value.

Figure 5: Output Adjustment shows how the ADJ pin is connected: -

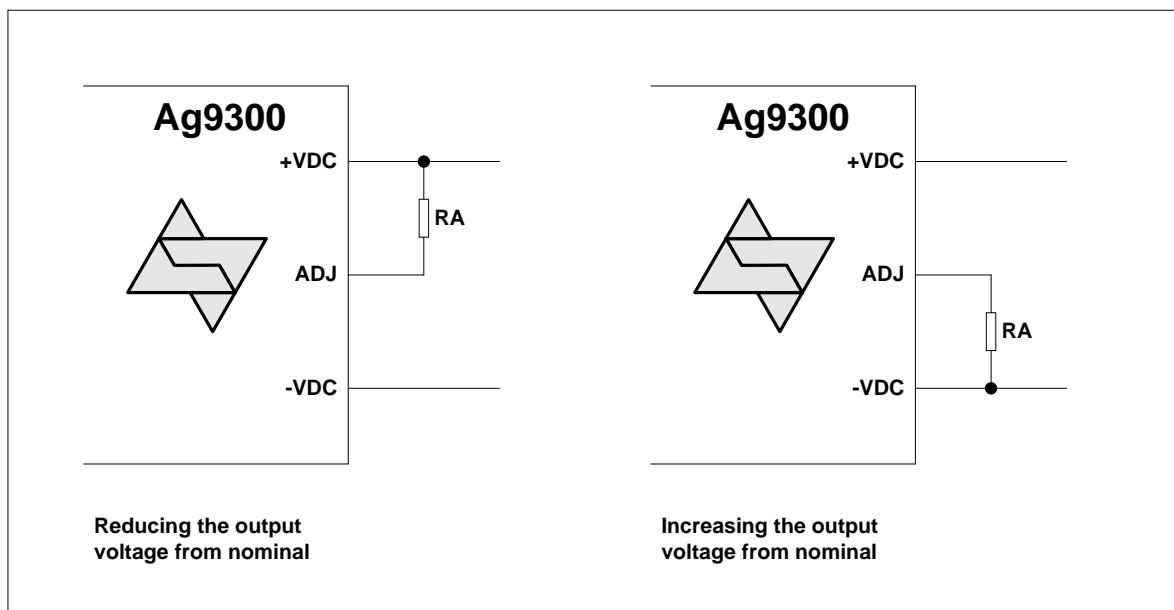

Figure 5: Output Adjustment

Reducing the output voltage, connect RA between ADJ and +VDC	
Value of RA	Ag9300 output
Open Circuit	12.0V
0 Ohms	8.8V
Increasing the output voltage, connect RA between ADJ and GND	
Value of RA	Ag9300 output
Open Circuit	12.0V
0 Ohms	13.4V

Table 3: Output Adjustment Resistor (R) Value

*Note: the Ag9300 maximum load current is 1A.

5.7. Typical Connections

The Ag9300 only requires a few external components - the bridge rectifiers on the VIN input are to conform to the IEEE802.3af input polarity protection requirement. The 470 μ F capacitor (C2) connected across the output is needed to cope with load step changes. This can be a low cost electrolytic capacitor (a minimum of 470 μ F 16V is recommended) as shown in Figure 6, this does not need to be a low ESR type.

The Class programming resistor RC is optional and provides great flexibility to the Ag9300. Further information on using this input can be found in section 5.4. Power Classification.

The output voltage can be adjusted by simply connecting a resistor between the ADJ pin and either the +VDC Pin or the -VDC pin, see section 5.6. Output Adjustment.

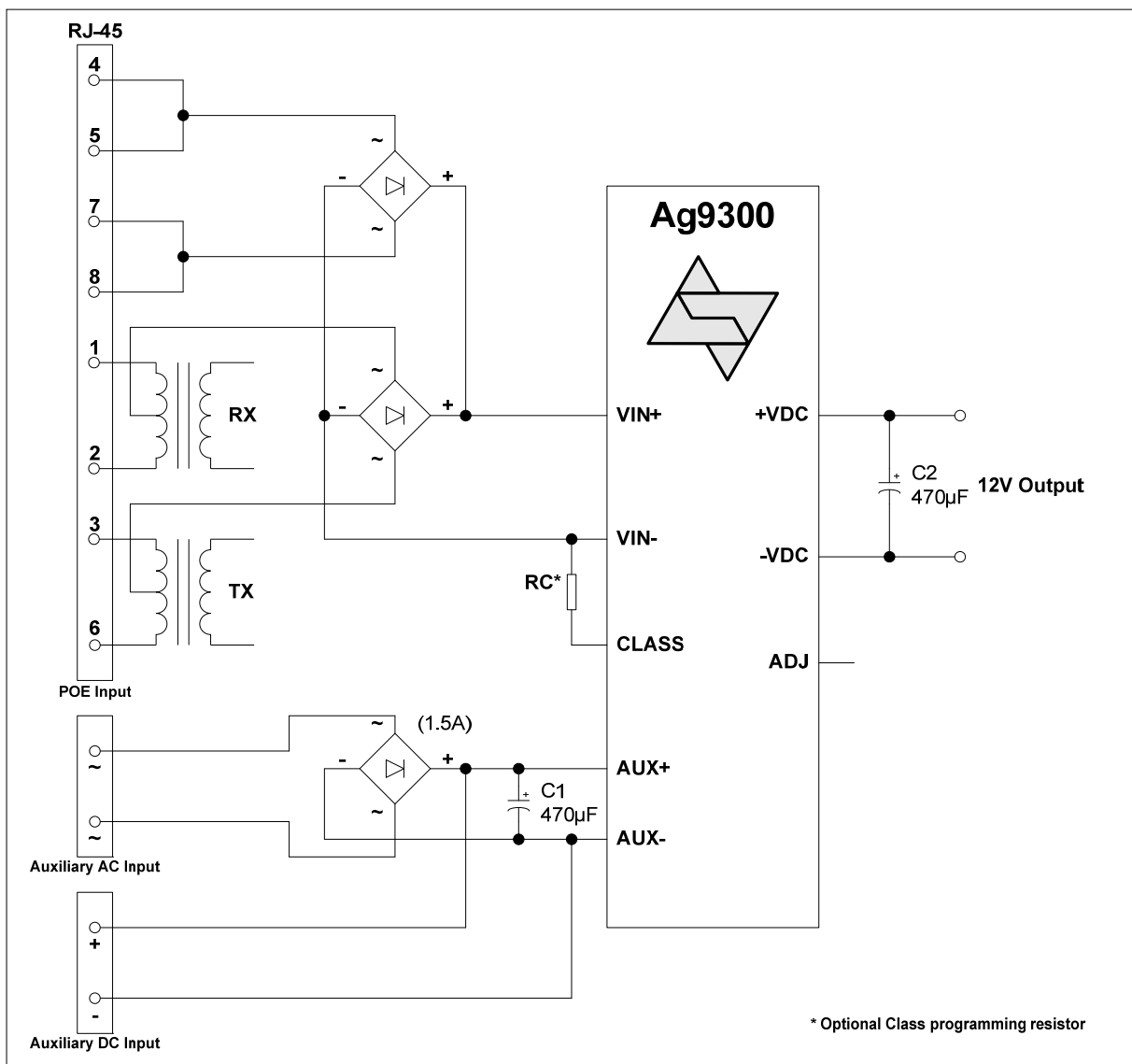

Figure 6: Typical Connection Diagram

Figure 6 shows two auxiliary inputs - The AC input requires an external bridge rectifier and 470µF capacitor, the DC input does not require these components. It would be acceptable to inject DC into the AC input, if polarity protection is required, but the voltage drop of the bridge rectifier will need to be taken into account. Using Schottky diodes in the bridge rectifiers will reduce the voltage drop and increase the overall efficiency figures.

6. Typical Application

The Ag9300 can be used in numerous applications. In the example shown in Figure 7, the data outputs from the switch are connected to the inputs of a midspan. The midspan will then add power (to the data) on each output that supports POE.

In this example port 1 is connected to an ethernet camera and port 2 is connected to a wireless access point, both of these devices have a built-in Ag9300. When the midspan is switched on (or when the device is connected), the midspan will check each output for a POE signature. On ports 1 and 2 the Ag9300 will identify themselves as POE enabled devices and the midspan will supply both data and power to these peripherals.

The other ports (shown in this example) will not have a PoE signature and the midspan will only pass the data through to these peripherals. The midspan will continuously monitor each output to see if a POE enabled device has been added or removed.

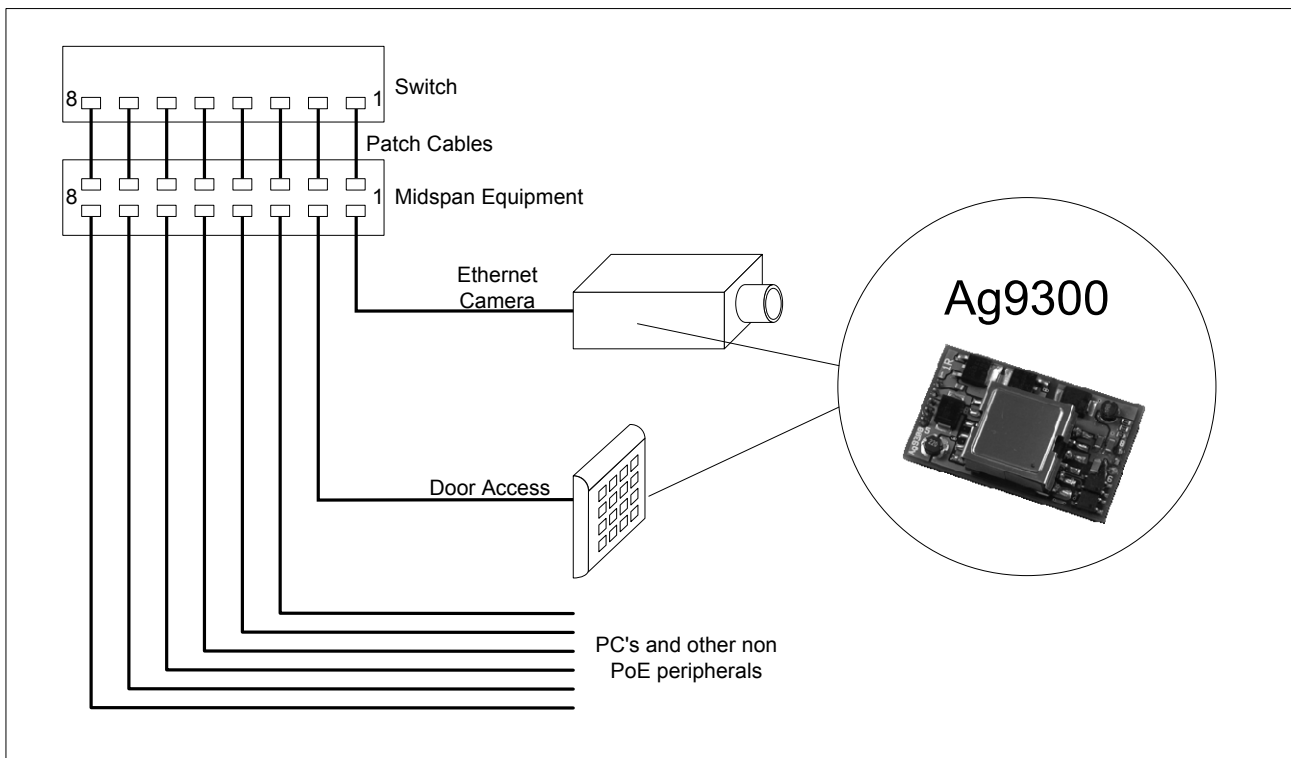

Figure 7: Typical Application

7. Typical Recommendations

Figure 8: Typical Layout gives an example of the tracking needed for the Ag9300. R1, R2 and R3 are optional components. C2 needs to be positioned close to the output pins of the Ag9300 as possible to minimise the current loop. The thermal performance of the Ag9300 can be improved by increasing the surface area of the output tracks (+VDC and -VDC). This is not applicable if the Ag9300 is in a socket.

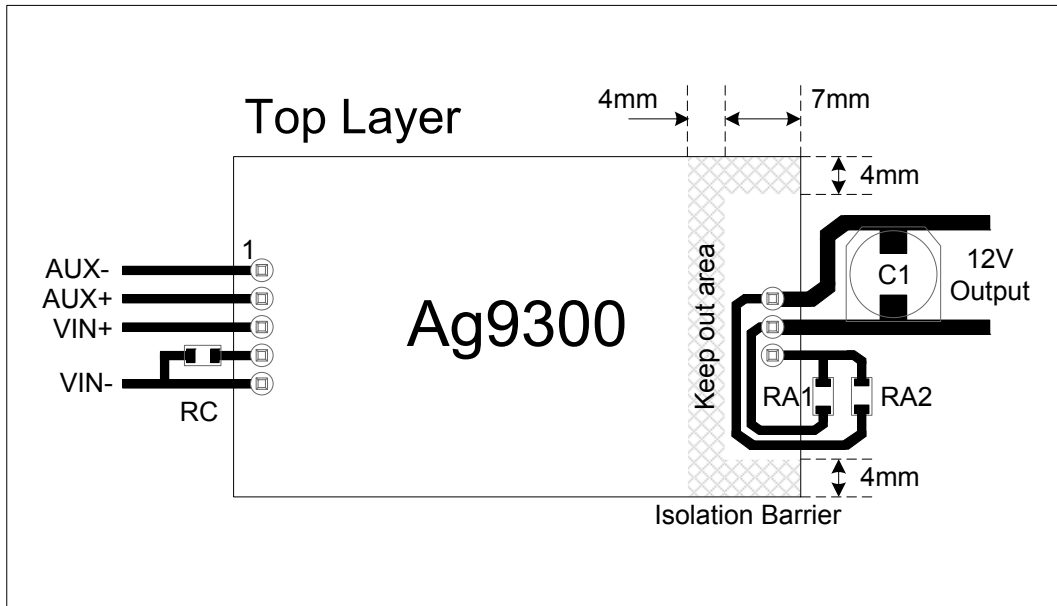

Figure 8: Typical Layout

8. Operating Temperature Range

Because the Ag9300 is a power component, it will generate heat, so it is important that this be taken into consideration at the design stage.

The heart of the Ag9300 is a DC/DC converter, which like any other power supply will generate heat. The amount of heat generated by the module will depend on the load it is required to drive and the input voltage supplied by the PSE. The information shown within this section of datasheet is referenced to a nominal 48Vdc input voltage supplied by the PSE.

The Ag9300 has a maximum ambient operating temperature of 70°C see Figure 9. These results are in still air without any heatsinking, the performance of the Ag9300 can be improved by forcing the airflow over the part or by using a heatsink (see the Ag9300 application note on heatsinking for more information).

Because each application is different it is impossible to give fixed and absolute thermal recommendations. However it is important that any enclosure used has sufficient ventilation for the Ag9300 and a direct airflow if possible.

Figure 9 show the maximum ambient temperature under different load conditions. These figure have been recorded in a sealed enclosure (in still air) using a heater element to elevate the ambient temperature (within the enclosure).

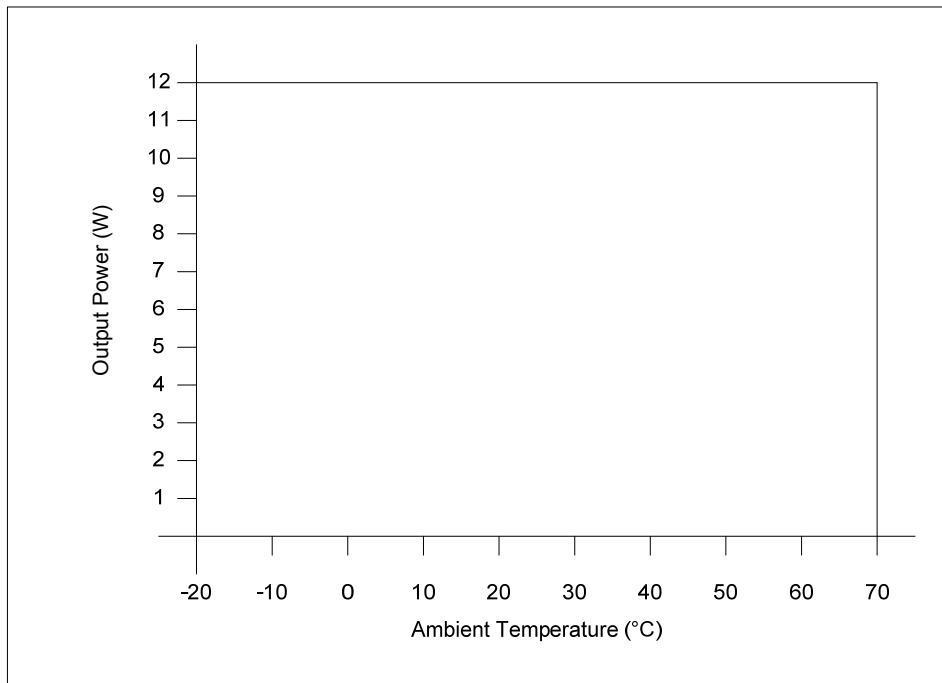

Figure 9: Ag9300 Operating Profile

9. Protection

The Ag9300 has built-in over-current and thermal protection to prevent the module from being damaged if operated beyond its power / temperature specification. If a short circuit is applied to the output the DC/DC converter will limit the current until the short circuit is removed. The thermal protection circuit will continue to disable the DC/DC converter until the Ag9300 temperature has cooled sufficiently.

The Ag9300 may be damaged by input voltage transients greater than 80V. If protection from electrostatic discharge (ESD) or other high voltage transients is required, it is recommended that over-voltage clamping devices are fitted across the VIN and AUX inputs. Typically an SMAJ58 will be sufficient; see Apps Note “ANX-POE-Protection”.

10. Electrical Characteristics

10.1. Absolute Maximum Ratings*

	Parameter	Symbol	Min	Max	Units
1	DC Supply Voltage	V_{CC}	-0.3	60	V
2	DC Supply Voltage Surge for 1ms	V_{SURGE}	-0.6	80	V
3	Storage Temperature	T_S	-40	+100	°C

*Exceeding the above ratings may cause permanent damage to the product. Functional operation under these conditions is not implied. Maximum ratings assume free airflow.

10.2. Recommended Operating Conditions

	Parameter	Symbol	Min	Typ	Max	Units
1	POE Input Supply Voltage	V_{INPOE}	36	48	57	V
2	AUX Input Supply Voltage	V_{INAUX}	10.8 18		50 40	Vdc Vac
3	POE Input Under Voltage Lockout	V_{LOCK}	30		36	V
4	Operating Temperature	T_{OP}	0	25	70†	Ta / °C

†See Section 8. Operating Temperature Range

10.3. DC Electrical Characteristics*

	DC Characteristic	Sym	Min	Typ*	Max	Units	Test Comments
1	Nominal Output Voltage	V_{OUT}	11.5	12	12.5	V	
2	Output Current ($V_{IN} = 48V$ or $V_{AUX} = 16Vdc$) Output Current ($V_{AUX} = 12Vdc$)	I_{OUT}			1.0 0.7	A A	
3	Line Regulation $V_{IN} = 36V$ to $57V$ @ max load**	V_{LINE}		0.1		%	
4	Load Regulation min to max load ($V_{IN} = 48V$)**	V_{LOAD}		1		%	
5	Output Ripple and Noise Max load †	V_{RN}		50		mVp-p	
6	Minimum Load	R_{LOAD}		100		mA	for specified regulation ‡
7	Short-Circuit Duration	T_{SC}			∞	sec	Continuous @ $50^{\circ}C$, $V_{IN}=48V$
8	Efficiency @ 100% Load, $V_{IN}=48V$	EFF		82		%	
9	Isolation Voltage (I/O)	V_{ISO}			1500	V_{PK}	Impulse Test

*Typical figures are at 25°C with a nominal 48V supply and are for design aid only. Not Guaranteed

**After 5 minutes

†The output ripple and noise can be reduced with an external filter, see application note.

‡Can be used with no load at reduced voltage regulation.

11. Package

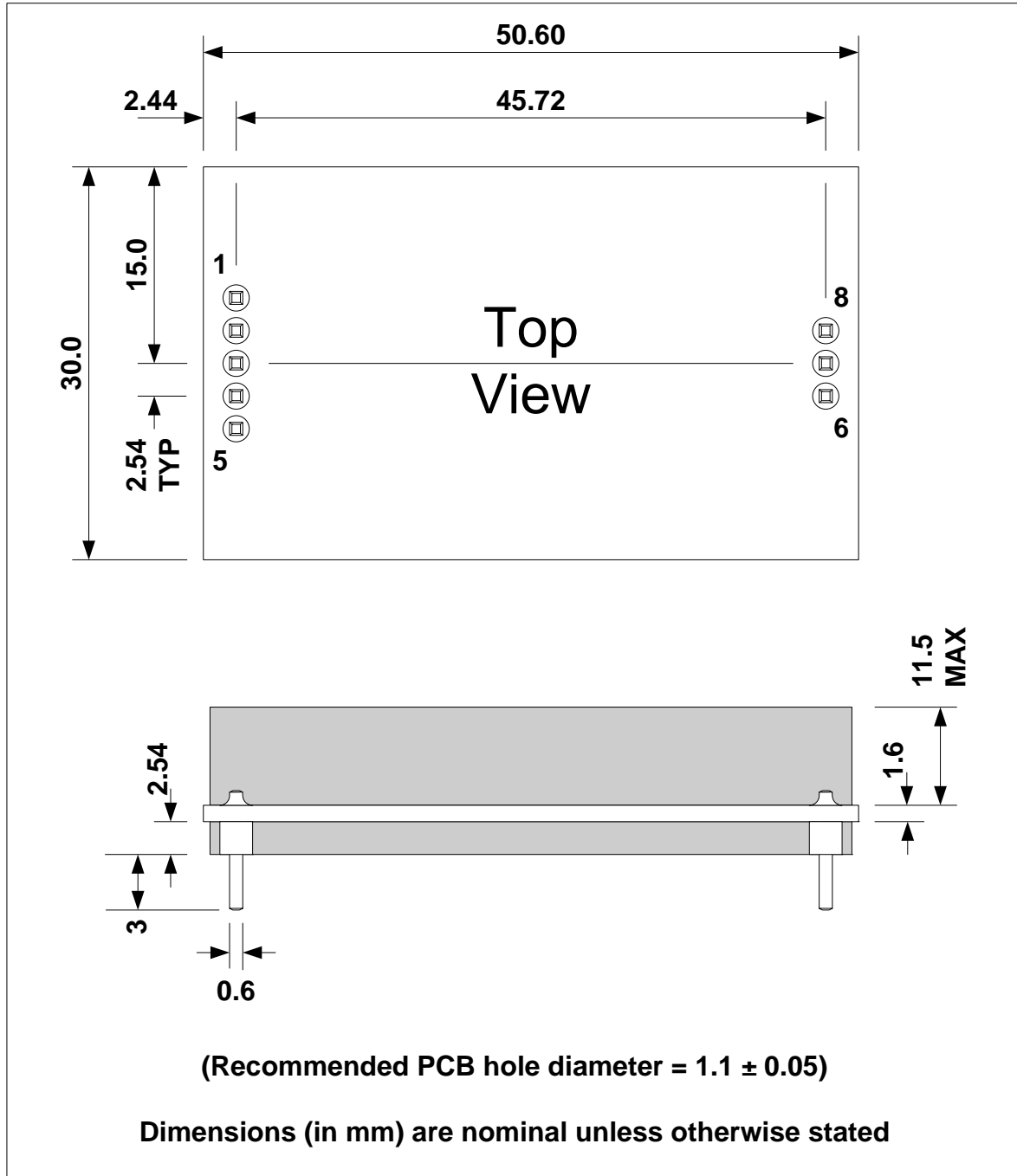

Information published in this datasheet is believed to be correct and accurate. Silver Telecom assumes no liability for errors which may occur or for liability otherwise arising out of use of this information or infringement of patents which may occur as a result of such use. No license is granted by this document under patents owned by Silver Telecom or licensed from third parties by Silver Telecom. The products, their specification and information appearing in this document are subject to change by Silver Telecom without notice.